

AIR BREAK WATERS TANKS



GENERAL CHARACTERISTICS

The air break tanks produced by Kenta prevent all water reflux problems due to waterworks depression. The water level in the tank is maintained by micro-switches; a special valve is provided to mechanically stops the water flow in extreme cases. This product is entirely manufactured in food-grade materials.

TYPICAL APPLICATIONS

Vending machines

Icemakers

Coffee machines

CONSTRUCTIVE CHARACTERISTICS

The tanks are available in two models:

- With flow valve, with or without level control micro-switches.
- With float valve and level control micro-switches.
- All models are entirely manufactured in food-grade approved plastic materials.

DESIGN AND OVERALL DIMENSIONS

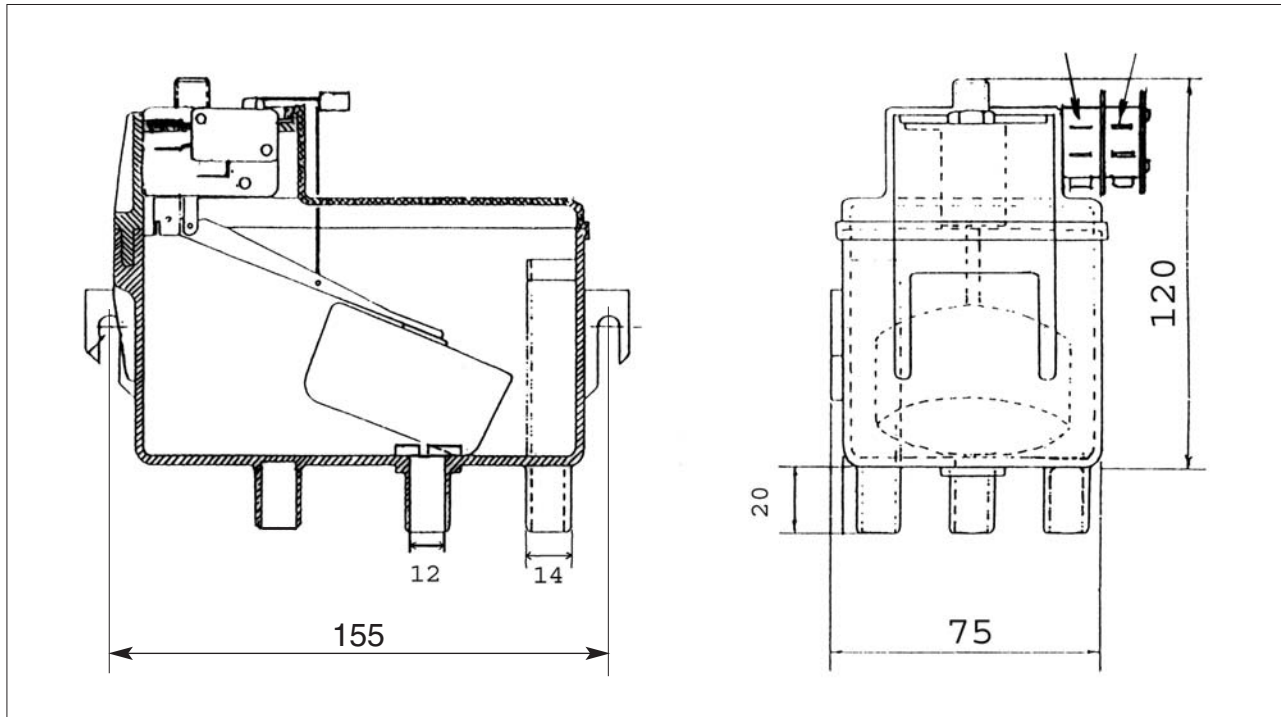

USEFUL INFORMATION

- **Room temperature.**

The components can be used at room temperatures between + 5° and +40° C.

- **Available on request:**

Inlet and outlet holes in different diameters.

Blind inlet and outlet holes.

Pipe connections in different diameters.

- **Customized models.**

Customized models can be produced by special quantity orders.